

Aug.1.2018 Copyright 2018 HIROSE ELECTRIC CO., LTD. All Rights Reserved.  
 In case that the application demands a high level of reliability, such as automotive,  
 please contact a company representative for further information.

| COUNT | DESCRIPTION OF REVISIONS | B | Y | CHKD | DATE | COUNT | DESCRIPTION OF REVISIONS | B | Y | CHKD | DATE |
|-------|--------------------------|---|---|------|------|-------|--------------------------|---|---|------|------|
| △     |                          |   |   |      |      | △     |                          |   |   |      |      |
| △     |                          |   |   |      |      | △     |                          |   |   |      |      |
| △     |                          |   |   |      |      | △     |                          |   |   |      |      |

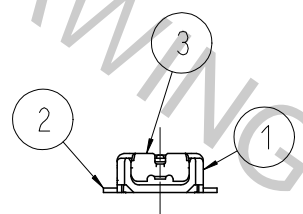

A-A (50:1)

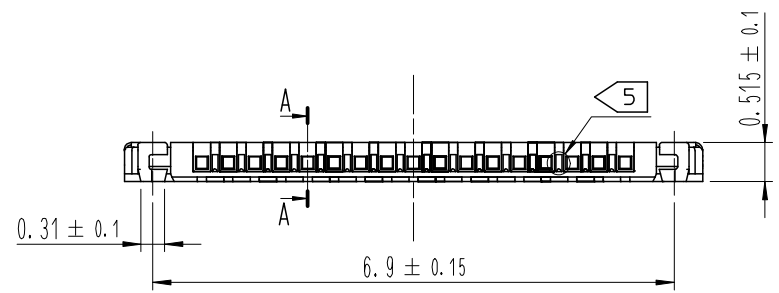
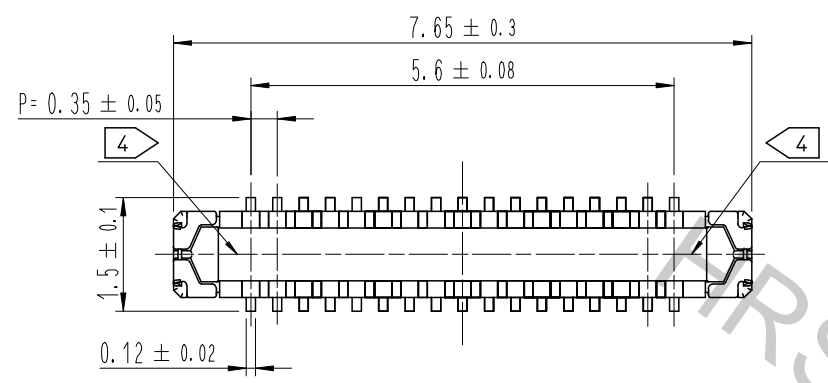
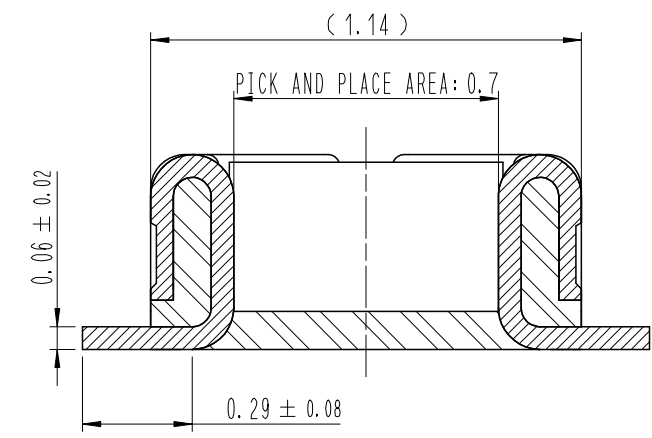

ENGAGEMENT FIGURE (50:1)

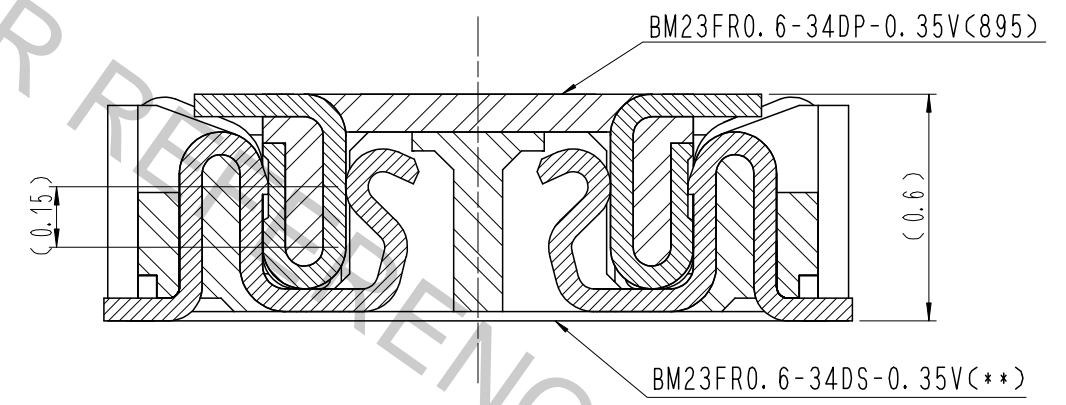

DRAWING FOR REFERENCE  
 This is subject to change without notice

- NOTE
- 1 . ALL LEAD CO-PLANARITY SHALL BE 0.08mm MAX.
  - 2 CONTACT PLATING SPECIFICATIONS.  
 CONTACT AREA : GOLD 0.05 μm MIN.  
 SMT LEAD : GOLD 0.05 μm MIN.  
 UNDER PLATING : NICKEL 1 μm MIN.  
 ( SURFACE : SEALING )
  - 3 METAL FITTING PLATING SPECIFICATIONS.  
 SMT LEAD : GOLD 0.05 μm MIN.  
 UNDERPLATING : NICKEL 1 μm MIN.  
 ( SURFACE : SEALING )
  - 4 HRS MARK AND CAV No. ARE INDICATED IN APPROX POSITION SHOWN.
  - 5 A PART OF THE WALL COULD BE NOTCHED.

| 4   | PS           | CLEAR (EMBOSSED CARRIER TAPE) |     |           |                              |
|-----|--------------|-------------------------------|-----|-----------|------------------------------|
| 3   | COPPER ALLOY | 3                             | 7   | PS        | CLEAR (REINFORCEMENT COLLAR) |
| 2   | COPPER ALLOY | 2                             | 6   | PS        | BLACK (PLASTIC REEL)         |
| 1   | LCP          | UL94 V-0, BLACK               | 5   | POLYESTER | CLEAR (COVER TAPE)           |
| NO. | MATERIAL     | FINISH, REMARKS               | NO. | MATERIAL  | FINISH, REMARKS              |

| REMARKS |  |  |  |  | DRAWN      | DESIGNED   | CHECKED  | APPROVED   | RELEASED |
|---------|--|--|--|--|------------|------------|----------|------------|----------|
|         |  |  |  |  | S. H. JUNG | S. H. JUNG | H. W. JO | T. S. KANG | 17.05.08 |
|         |  |  |  |  | 17.05.08   | 17.05.08   | 17.05.08 | 17.05.08   | 17.05.08 |

|                |       |             |             |          |                           |
|----------------|-------|-------------|-------------|----------|---------------------------|
| CODE NO. (OLD) |       | DRAWING NO. | EDC3-631843 | PART NO. | BM23FR0.6-34DP-0.35V(895) |
|                | SCALE |             |             | CODE NO  | CL 6644-0005-8-895        |
|                | 10:1  |             |             |          |                           |
|                | UNITS |             |             |          |                           |
|                | mm    |             |             |          |                           |
|                |       |             |             |          | 1/3                       |

Aug.1.2018 Copyright 2018 HIROSE ELECTRIC CO., LTD. All Rights Reserved.  
 In case that the application demands a high level of reliability, such as automotive,  
 please contact a company representative for further information.

7 RECOMMENDED PCB LAYOUT

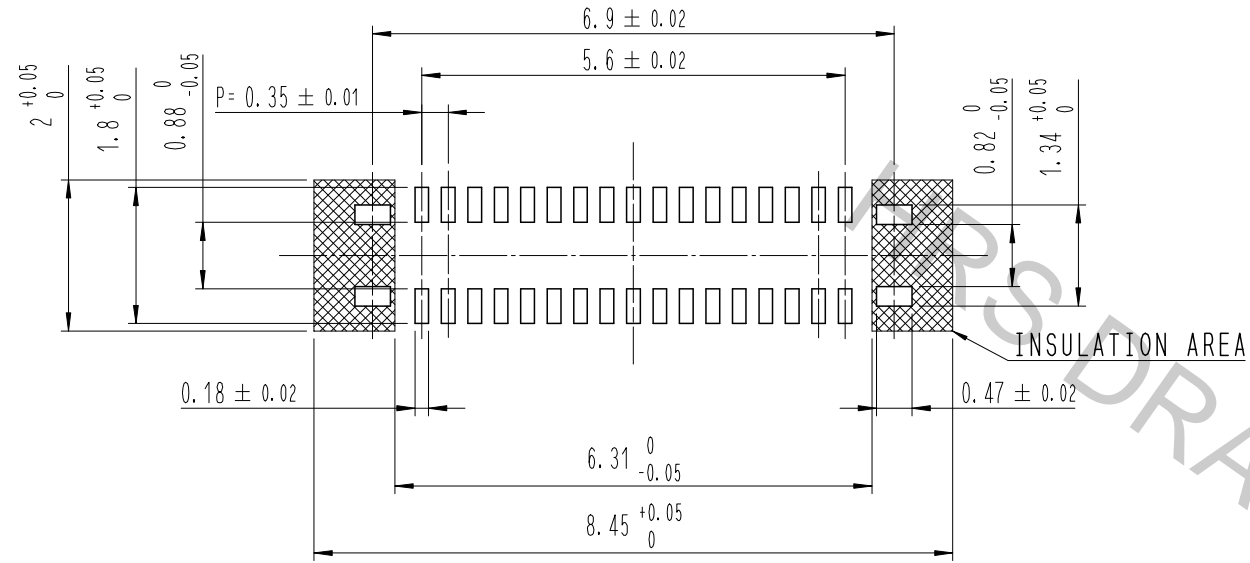

RECOMMENDED METAL MASK DIMENSIONS

METAL MASK THICKNESS : 100 μm

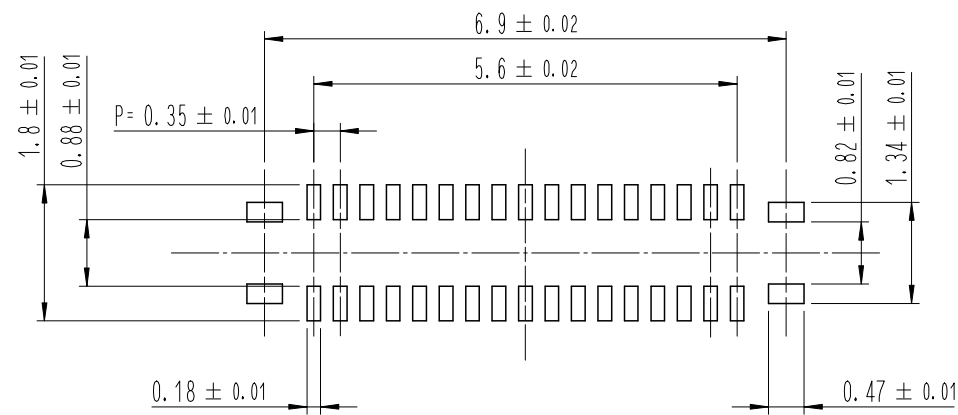

6 RECOMMENDED REFLOW TEMPERATURE PROFILE USING LEAD-FREE SOLDER PASTE.

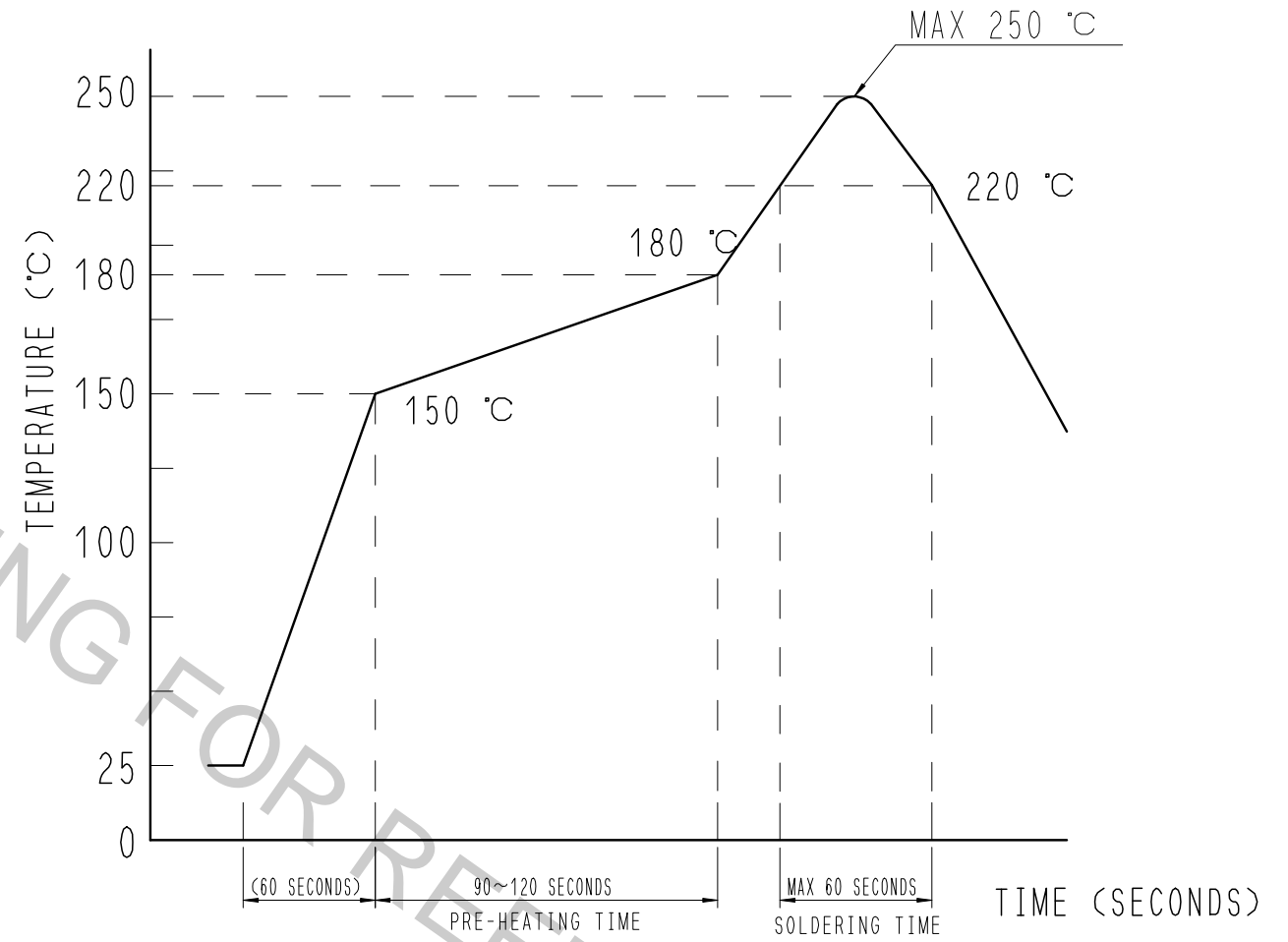

REFLOW METHOD: N2 REFLOW  
 NUMBER OF REFLOW CYCLES: 2 CYCLES MAX.  
 1) REFLOW TIME  
 DURATION ABOVE 220°C, 60 SEC MAX.  
 (PEAK TEMPERATURE: 250°C MAX)  
 2) PRE-HEAT TIME  
 PRE-HEAT TEMPERATURE (MIN): 150°C  
 PRE-HEAT TEMPERATURE (MAX): 180°C  
 PRE-HEAT TIME: 90-120 SEC.

- 6 THIS TEMPERATURE PROFILE IS PER THE CONDITIONS SHOWN ABOVE. ADDITIONAL FACTORS, SUCH AS SOLDER PASTE TYPE, PCB SIZE AND OTHER MOUNTED COMPONENTS COULD AFFECT THE PROFILE. THEREFORE, A THOROUGH EVALUATION OF MOUNTING CONDITION IS REQUIRED PRIOR TO PRODUCTION. TEMPERATURE IS MEASURED AT CONTACT LEAD.
- 7 PLEASE CONTACT US IN CASE YOU WILL MAKE DIFFERENT SETTINGS FROM OUR RECOMMENDATION.

|       |             |                            |          |                           |
|-------|-------------|----------------------------|----------|---------------------------|
|       | DRAWING NO. | EDC3-631843                | PART NO. | BM23FR0.6-34DP-0.35V(895) |
|       | SCALE       | 10:1                       | CODE NO  | CL 6644-0005-8-895        |
| UNITS | mm          | HRS HIROSE KOREA CO., LTD. |          | 2/3                       |

Aug.1.2018 Copyright 2018 HIROSE ELECTRIC CO., LTD. All Rights Reserved.  
 In case that the application demands a high level of reliability, such as automotive,  
 please contact a company representative for further information.

EMBOSSED CARRIER TAPE PACKAGING (5:1)

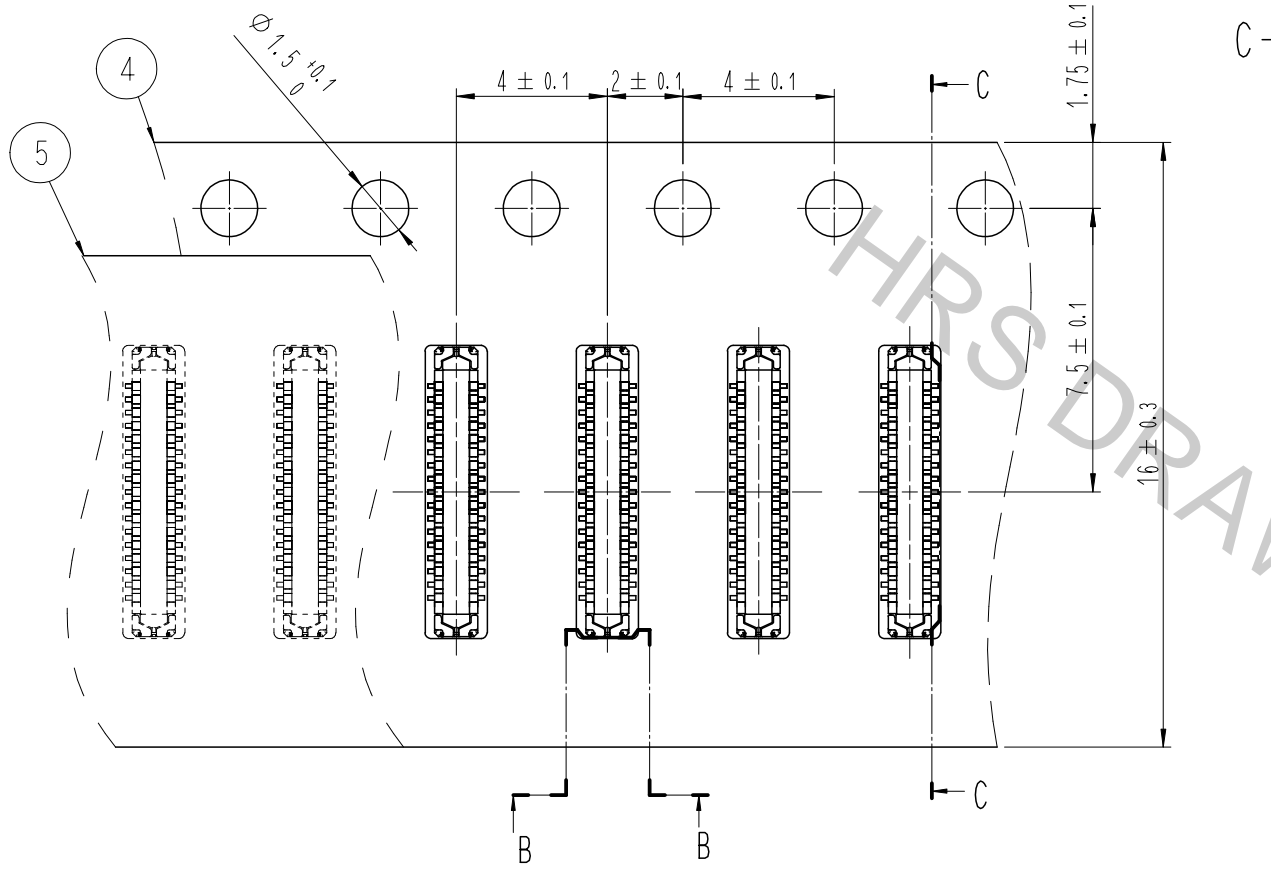

C-C (5:1)

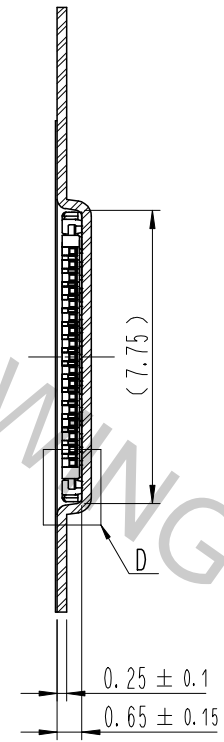

B-B (5:1)

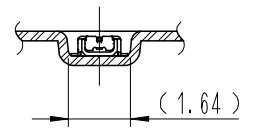

DIRECTION OF UNREELING

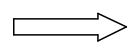

10 TAPING(FREE)

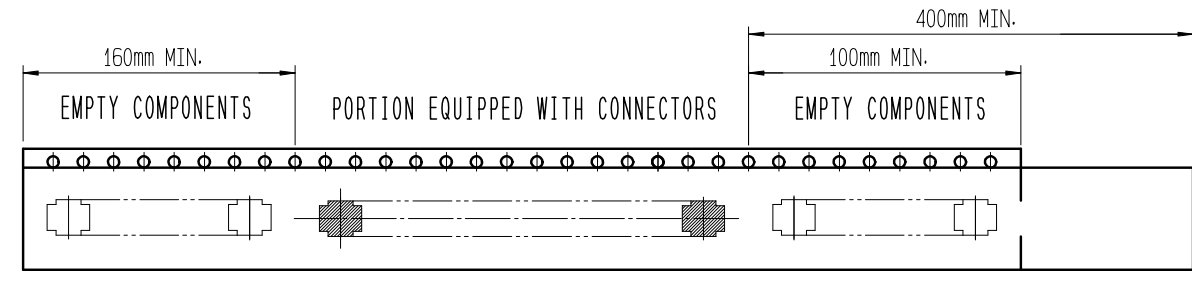

STYLE AND DIMENTION OF REEL (FREE)

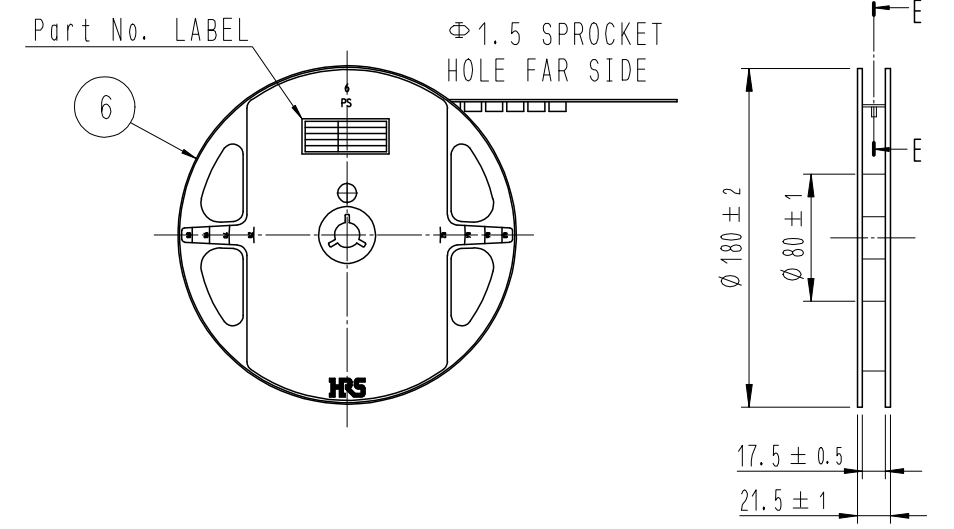

E-E (FREE)

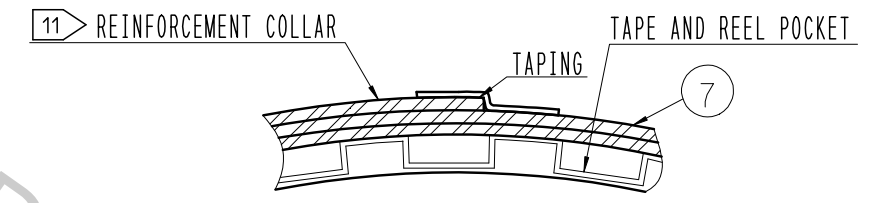

DETAIL OF PART No. LABEL

|                      |                           |
|----------------------|---------------------------|
| SUPPLIER             |                           |
| QUANTITY             |                           |
| PART NO.             |                           |
| CODE NO.             |                           |
| DATE OF MANUFACTURED |                           |
| 生産月日                 | 年 月 日                     |
| 図番                   | ** ** *                   |
| 品名                   | BM23FR0.6-34DP-0.35V(895) |
| 納入数量                 | 1,000個                    |
| 納入者                  | HIROSE KOREA              |

- 8 . PER REEL 1,000 CONNECTORS.
- 9 . THE DIMENSIONS IN PARENTHESES ARE FOR REFERENCE.
- 10 REFER TO JIS C 0806, IEC-60286-3 (PACKAGING OF COMPONENTS FOR AUTOMATIC HANDLING)
- 11 AFTER PACKAGING, ROLL 2 METERS OF THE REINFORCEMENT COLLAR TO OUTER CIRCUMFERENCE OF TAPE AND REEL POCKET, AND TAPE DOWN AT THE END THE COLLAR.

|                            |                                       |                                |     |
|----------------------------|---------------------------------------|--------------------------------|-----|
| DRAWING NO.<br>EDC3-631843 | PART NO.<br>BM23FR0.6-34DP-0.35V(895) | CODE NO.<br>CL 6644-0005-8-895 | 3/3 |
|                            |                                       |                                |     |
| UNITS<br>mm                |                                       | HRS HIROSE KOREA CO., LTD.     |     |